



## DXP - GO Switch

The DXP combines position sensors, internal mount pilot device and an on-board spool valve into a single enclosure.

- Intrinsically Safe Class I, Div.1, Groups A, B, C, D (EEx ia IIC, II 1 G)
- Explosion-proof Class I, Div.1, Groups C & D (EEx d IIB, II 2 G)
- SPDT contact switches
- Integral Solenoid Pilot Valve (24Vdc, 110Vac and Intrinsically Safe)



### Table of Contents

2	Outline Dimensions
2	Indicator Assembly
3	DXP Enclosure Assembly
5	Spool Valve Assembly
5	Pilot Device Assembly
6	GO Switch Assembly
6	Shaft / Cam Assembly
7	Approvals & Warranty



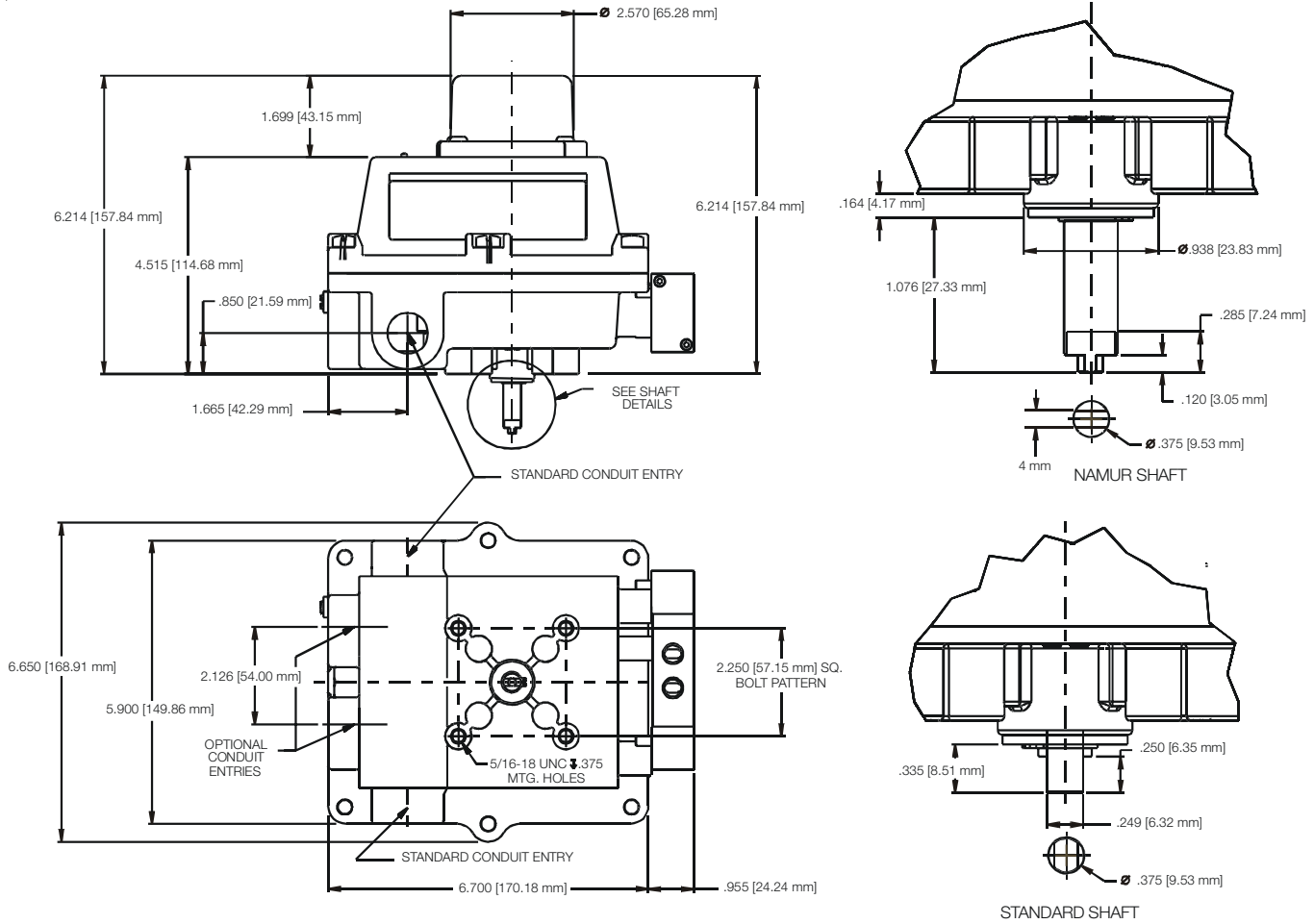

**Illustration #1 : Outline Dimensions**

**Installation Notes**

1. Be cautious not to allow undue axial (thrust) load on the DXP shaft.
2. Cycle the valve a couple of times prior to final tightening of the mounting kit hardware. This allows the shaft to self-center in the pinion slot, or coupler.
3. Always use sound mechanical practices when torquing down any hardware or making pneumatic connections.
4. This product comes shipped with plastic plugs in the conduit entries in an effort to protect the internal components from debris during shipment and handling. **It is the responsibility of the receiving and/or installing personnel to provide appropriate permanent sealing devices to prevent the intrusion of debris, or moisture, when stored outdoors or when installed.**
5. **It is the responsibility of the installer, or end user, to install this product in accordance with the National Electrical Code (NFPA 70), or any other national or regional code defining proper practices.**



**Illustration #2 : Indicator Assembly**

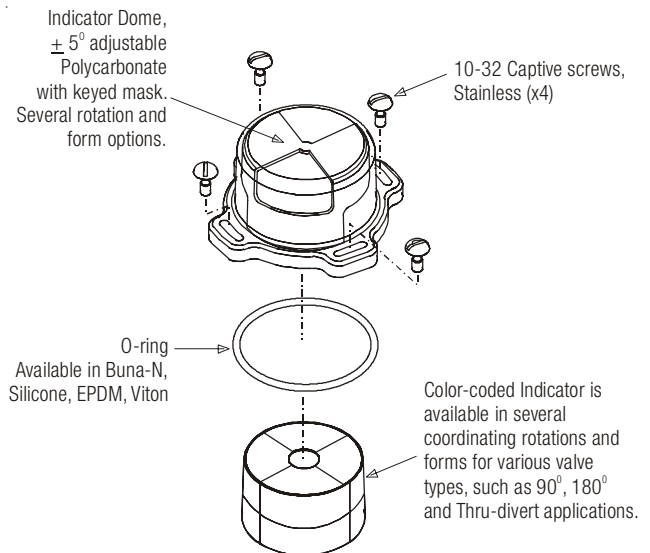

Indicator / Dome Replacement Kits	
AV-GB002	90°, Green/Open, Red/Closed, Buna oring
AV-YB002	90°, Yellow/Open, Blk/Closed, Buna oring
AV-TB002	90°, Green/Thru, Red/Divert, Buna oring
AV-4B002	45°, Green/Open, Red/Closed, Buna oring

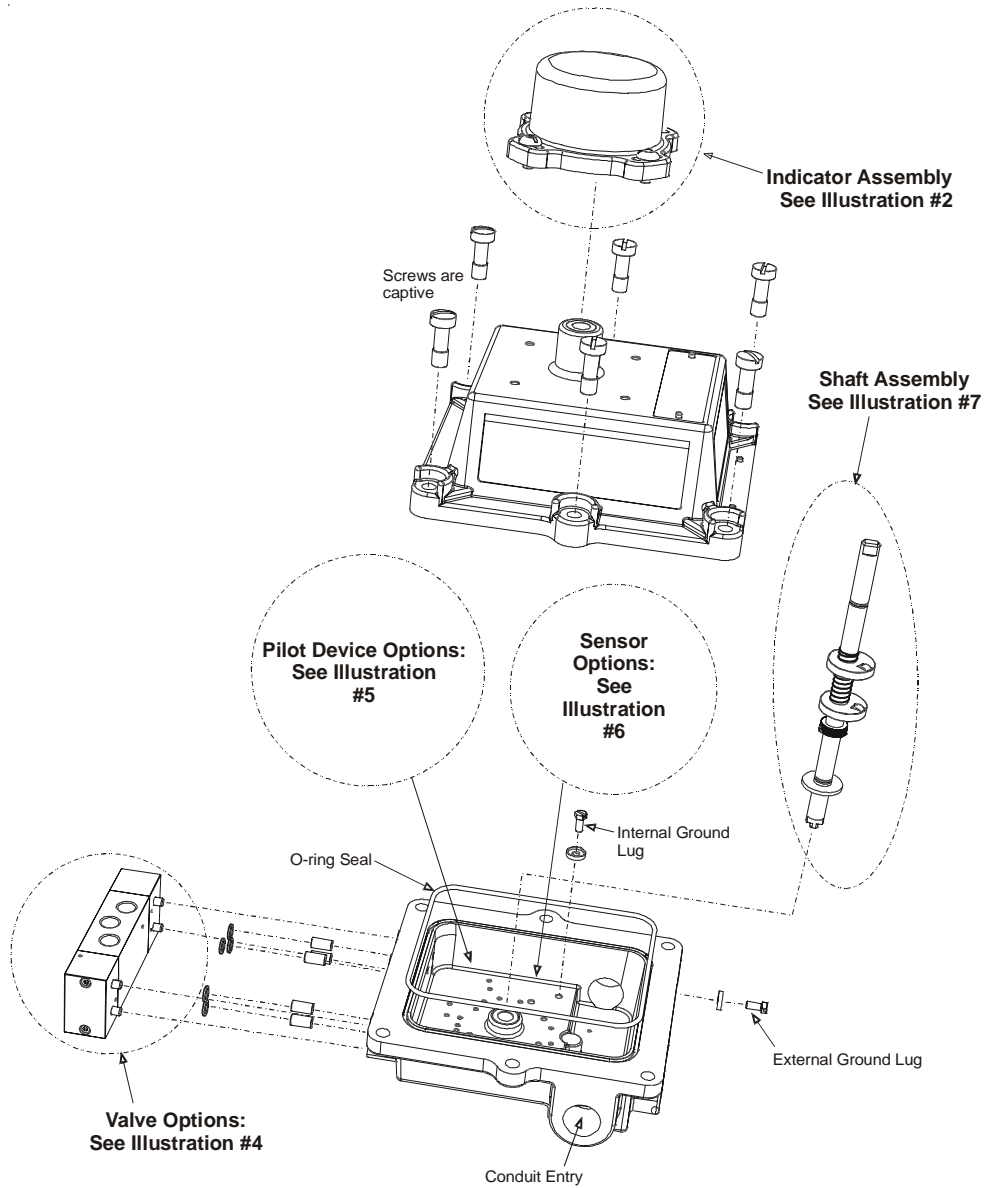

**Illustration #3 : DXP Enclosure Assembly**

Enclosure Specifications / Materials of Construction	
<b>Enclosure</b>	Die-cast A360 aluminum with dichromate conversion coating inside and out & epoxy coated exterior
<b>Fasteners</b>	Qty 6: M8 socket head bolt - stainless steel (6mm wrench)
<b>Shaft Bushings</b>	Cast-in Oilite bronze
<b>Seals</b>	O-ring seals available in: Buna-N, Silicone, EPDM & Viton
<b>Conduit Entries</b>	Quantity 2-4 available in: 3/4 NPT, 1/2 NPT, M20 & M16
<b>Mounting Holes</b>	(4X) 5/16-18 UNC tapped holes on 2.25"(57.15mm) Square Pattern, Optional F05 Pattern

Maximum Torque Values for Fasteners		
Description	Type	Max. Torque
Enclosure Lid Screws	See spec Table	8 ft.lbs.
Indicator Dome Screws	10-32 UNF	20 in.oz.
Bottom Mounting Holes	5/16-18 UNF	10 ft.lbs.

## Pneumatic Hookup Procedures

Prior to connecting the supply air to the spool valve, flush the system to remove any debris or contaminants. Galvanized pipe can easily flake and contaminate the system and therefore is not recommended.

### 4-Way Spool Valves

The TopWorx spool valve is a 5 port, 4-way valve driven by an internally mounted pilot valve. The spool valve supply port and work ports are 1/4" NPT. The exhaust ports are 1/8" NPT, marked as follows for the DXP:

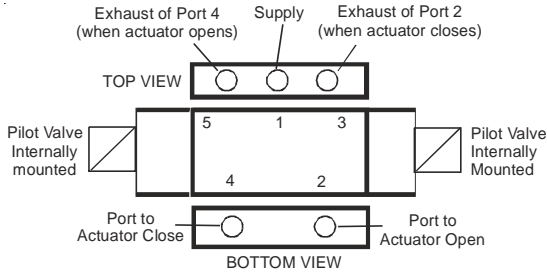

**\*\*\*NEVER PLUG, OR BLOCK, PORT 5\*\*\***

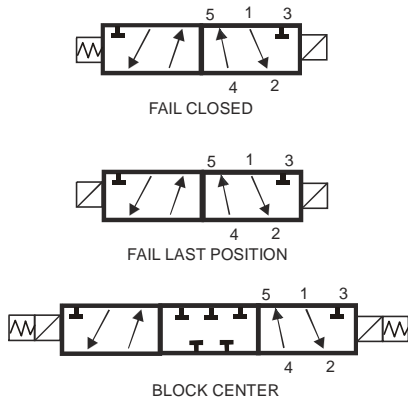
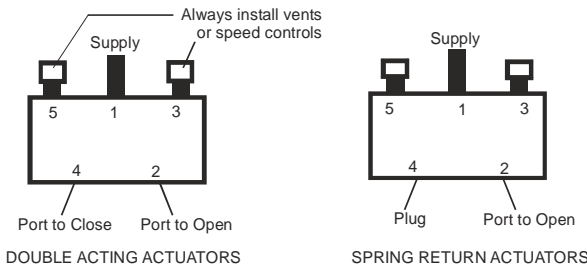

### Highly Recommended

TopWorx highly recommends Locktite 567 brand thread sealant. Do not use a hard setting pipe compound. If Teflon thread seal tape is used, start the wrap on the second thread from the leading thread of the fitting. This will prevent tape shreds from contaminating the spool valve seals.

Flow controls (AL-M21) or Breathers (AL-M31) should be installed in the exhaust ports to keep debris from falling into the spool valve and damaging the seals. This must be addressed prior to installation, or storage.

Spool Valve Specifications	
Medium	Dried, filtered air (40 micron)
Max Operating Pressure	100psi (0.7MPa) (6.89Bar)
Min Operating Pressure	30psi (0.28MPa) (2.76Bar)
Ambient Temperature Range	Refer to Product Nameplate Marking
Flow Coefficient	1.2Cv / 1.0Cv for Cold Temp
Environment Rating	Type 4, 4X, IP67
Port Size	1/4" NPT
Manual Override	Available in: Latching/non-latching Push Type & Palm Actuator Type
Valve Body	Available in: Hardcoat Anodized Aluminum, 304 & 316 Stainless
Valve Seals	Spool seals: Buna-N Valve Body Seals available in: Buna-N, Silicone, EPDM & Viton. Cold Temp Spools are lap-joint technology containing no seals.

### Don't forget!

TopWorx has a complete line of breathers, flow controls, regulators and filters.

Check out [www.topworx.com](http://www.topworx.com) or call us at 502.969.8000 for more details

**DID YOU KNOW?** TopWorx manufactures the globally-known GO Switch Leverless Limit Switch, which comprises a full line of harsh environment sensors. If your application is very cold, very hot, under water or in a caustic atmosphere, then GO Switch has the answer.

Fail Closed Spool Valve Replacement Assemblies	
AV-BFCVA20	Std Alum Spool Va Assy w/Buna seals
AV-BFCVS20	Std 304ss Spool Va Assy w/Buna seals
AV-BFCV620	Std 316ss Spool Va Assy w/Buna seals

Fail Last Position Spool Valve Replacement Assemblies	
AV-BFLPVA20	Std Alum Spool Va Assy w/Buna seals
AV-BFLPVS20	Std 304ss Spool Va Assy w/Buna seals
AV-BFLPV620	Std 316ss Spool Va Assy w/Buna seals

Block-Center Spool Valve Replacement Assemblies	
AV-BBCVA20	Std Alum Spool Va Assy w/Buna seals
AV-BBCVS20	Std 304ss Spool Va Assy w/Buna seals
AV-BBCV620	Std 316ss Spool Va Assy w/Buna seals

Consult factory for more options.

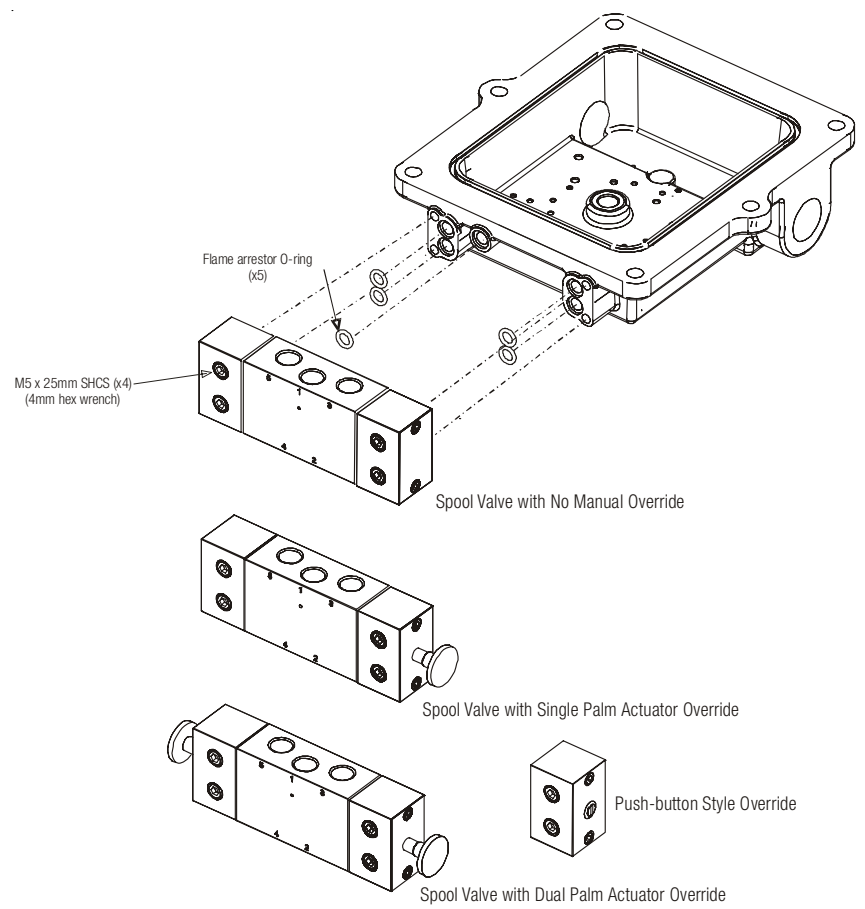

**Illustration #4 : Spool Valve Assembly**

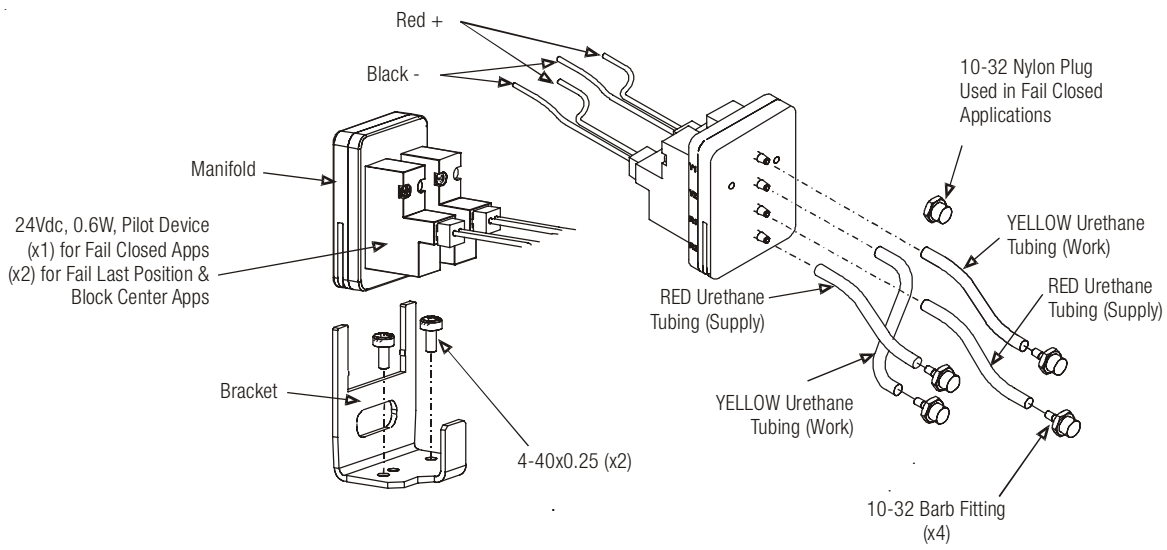

**Illustration #5 : Pilot Device Assembly**

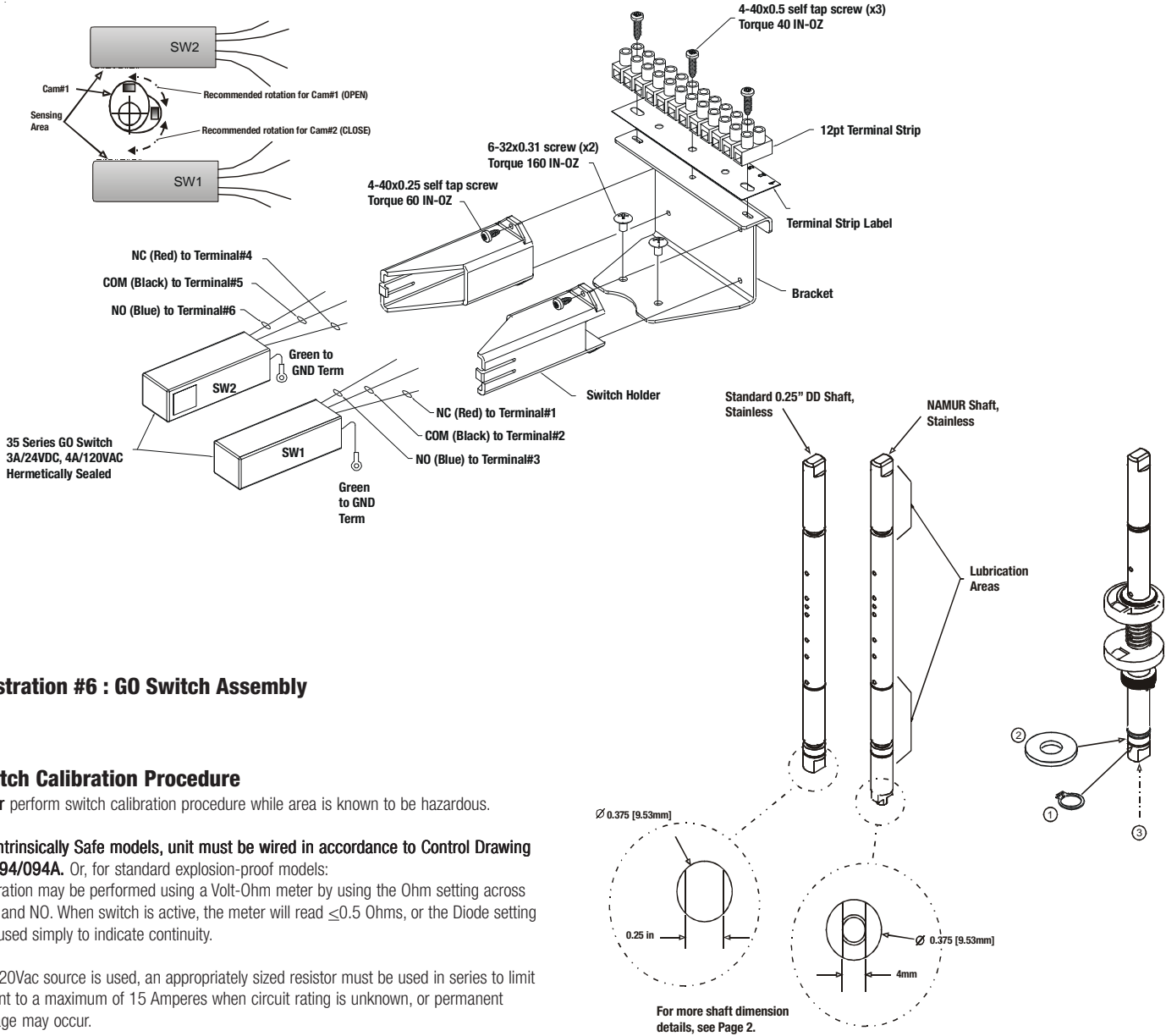

**Illustration #6 : GO Switch Assembly**

**Switch Calibration Procedure**

Never perform switch calibration procedure while area is known to be hazardous.

For Intrinsically Safe models, unit must be wired in accordance to Control Drawing S-K094/094A. Or, for standard explosion-proof models: Calibration may be performed using a Volt-Ohm meter by using the Ohm setting across COM and NO. When switch is active, the meter will read  $\leq 0.5$  Ohms, or the Diode setting may used simply to indicate continuity.

If a 120Vac source is used, an appropriately sized resistor must be used in series to limit current to a maximum of 15 Amperes when circuit rating is unknown, or permanent damage may occur.

**Step 1:** With valve in the CLOSED position, disengage the BOTTOM Cam from the splined Hub and rotate Clockwise until SW1 activates. Release Cam to re-engage splined Hub.

**Step 2:** Rotate valve to the OPEN position. Disengage the TOP Cam from the splined Hub and rotate Counter-clockwise until SW2 activates. Release Cam to re-engage the splined Hub.

**Step 3:** Cycle valve CLOSED and OPEN several times to insure switches will maintain calibration.

**For Reverse Acting actuators:**

**Step 1:** With valve in the CLOSED position, disengage the TOP Cam from the splined Hub and rotate Counter-clockwise until SW2 activates. Release Cam to re-engage the splined Hub.

**Step 2:** Rotate valve to the OPEN position. Disengage the BOTTOM Cam from the splined Hub and rotate Clockwise until SW1 activates. Release Cam to re-engage the splined Hub.

Repeat Step 3 above.

**Illustration #7 : Shaft / Cam Assembly (2 GO Switches)**

**Warranty**

TopWorx warrants that each item of new equipment manufactured by it will be free from defects in material and workmanship under normal use and service; its obligation under this Warranty, being limited to making good, at its factory, and part of parts thereof, which shall be returned to it with transportation charges prepaid, within one year after the date of the purchase of such equipment by the original purchaser, and which its examination shall disclose to its satisfaction to have been thus defective. TopWorx however, assumes no risk or liability for results of the use of the products purchased from it.

THIS WARRANTY IS IN LIEU OF ALL OTHER WARRANTIES, WHETHER OF MERCHANTABILITY FITNESS, OR OTHERWISE EXPRESSED OR IMPLIED, AND ALL OTHER OBLIGATIONS OR LIABILITIES AND TOPWORX NEITHER ASSUMES, NOR AUTHORIZES ANY PERSON TO ASSUME FOR IT ANY OTHER LIABILITY IN CONNECTION WITH THE SALE OF THIS EQUIPMENT.

No claims for labor in replacing defective parts and equipment and consequential damages will be allowed by the Company.

This Warranty shall not apply to equipment which has been subjected to misuse, negligence or accident.

This Warranty shall not apply to any equipment which shall have been repaired or altered, outside the Company's factory so as to affect such equipment's stability or reliability in the judgement of the Company.

**Illustration #6 : (4) GO Switch Assembly**

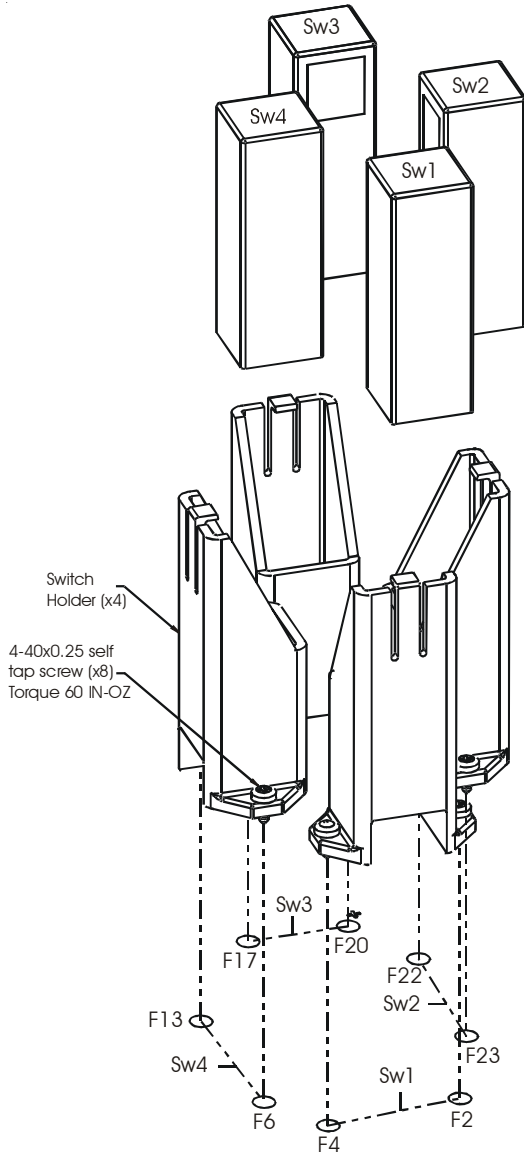

**Illustration #7 : Push Set Target Assembly (4 GO Switches)**

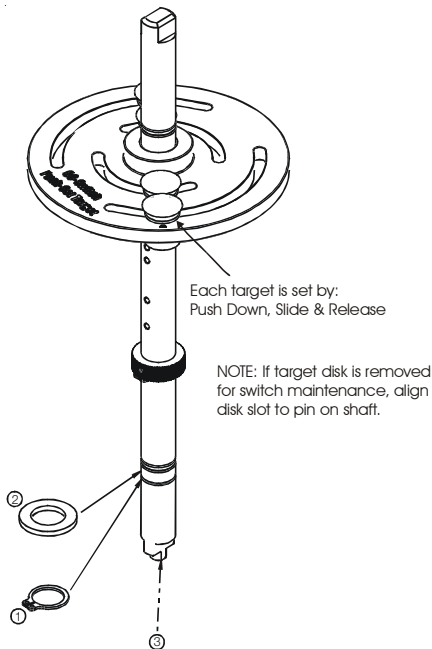

**Telemetering Equipment for use in Hazardous Locations**

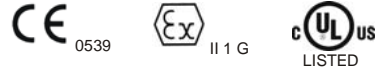

Zone 0 EEx ia IIC T4 -40°C ≤ Tamb ≤ 60°C; IP67  
 DEMKO 04ATEX130958X  
 Class I, Div.1 & 2, Groups A, B, C, D, T4; Type 4, 4X  
 Intrinsically Safe / Securite Intrinsic  
 Install per Control Drawing: S-K094/094A



Zone 1 EEx d IIB T6 -40°C ≤ Tamb ≤ 60°C; IP67  
 DEMKO 04ATEX0320446X  
 Class I, Div.1, Groups C & D, T6; Div.2, Groups A,B,C,D, T3  
 Type 4, 4X, 7  
 Max Current: 3A/24Vdc; 4A/120Vac (switches)  
 Pilot Coil: 24Vdc or 110Vac

**Special Conditions of Safe Use (All installations)**

Clean only with a damp cloth to prevent possibility of electrostatic discharge.

For Explosion Proof installations, the internal ground connection shall be used and the external ground connection, if supplied in addition, is supplemental bonding allowed where local authorities permit, or is required.

When installing with a third party listed nipple-mount solenoid, it is the responsibility of the installer to provide fittings, and apparatus, suitable for the area classification in accordance with the National Electrical Code.

All cable entry devices or conduit stopping boxes shall be certified in type of explosion protection 'd', suitable for the conditions of use and correctly installed.

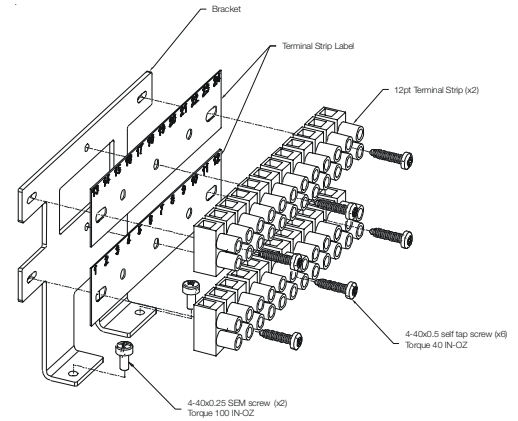

Switch 1		Switch 2	
Green to GND	Ground	Green to GND	Ground
COM (Black)	Terminal 2	COM (Black)	Terminal 5
NO (Blue)	Terminal 3	NO (Blue)	Terminal 6
NC (Red)	Terminal 1	NC (Red)	Terminal 4
Switch 3		Switch 4	
Green to GND	Ground	Green to GND	Ground
COM (Black)	Terminal 8	COM (Black)	Terminal 11
NO (Blue)	Terminal 9	NO (Blue)	Terminal 12
NC (Red)	Terminal 7	NC (Red)	Terminal 10

## About Valvetop™

Valvetop valve networking and control devices link on/off valves to process control systems via a variety of fieldbus protocols. Valvetop valve controllers and monitors support multiple bus protocols, operate in the most demanding plant conditions, and carry a variety of global approvals. Whether your application is rotary or linear, fieldbus or conventional, hazardous or general purpose, we have a suitable solution for you.

For inquiries, contact TopWorx at: 502.969.8000  
www.topworx.com  
info@topworx.com

## About TopWorx

TopWorx is the leader in field networking, valve control, and position sensing solutions for the process industries. Our products and services help plants, mills, and pipelines improve their performance by making it easy to implement modern automation technologies.



**Field Networking Solutions**

Network™ field networking products and services make it easy for plant personnel to understand, implement, and enjoy the benefits of modern bus networking technologies.



**Valve Control Solutions**

Valvetop™ valve networking and control solutions support multiple bus protocols, operate in the most demanding plant conditions, and carry a variety of global approvals.



**Position Sensing Solutions**

GO® Switch leverless limit switches provide reliable position sensing in extremely hot, cold, wet, dirty, corrosive, abusive, and explosive plant conditions.

# **TOPWORX**

3300 Fern Valley Road  
Louisville, Kentucky 40213 USA

502.969.8000 phone  
502.969.5911 fax  
info@topworx.com

**www.topworx.com**

TopWorx, Valvetop, Lumitech, GO Switch, and VIP are all trademarks of TopWorx, Inc.  
All other marks used in this document are the property of their respective owners.  
Information contained herein is subject to change without notice.

©TopWorx, Inc. All rights reserved.

S-K125 R3