

# Installation & Maintenance Instructions

3-WAY DIRECT-ACTING SOLENOID VALVES  
 UNIVERSAL OPERATION — 1/4" NPT — 1/16" ORIFICE  
 BRASS OR STAINLESS STEEL CONSTRUCTION  
 AIR OR INERT GAS SERVICE

SERIES

8314

Form No.V6855R1

**IMPORTANT:** See separate solenoid installation and maintenance instructions for information on: **Wiring, Solenoid Temperature, Causes of Improper Operation, Coil or Solenoid Replacement.**

## DESCRIPTION

Series 8314 valves are 3-way direct-acting solenoid valves designed for air or inert gas service. Valve bodies are made of rugged brass or stainless steel. The valves may be provided with a low power or intrinsically safe solenoid.

## OPERATION

**Universal** (Pressure at any orifice)

**Solenoid De-energized:** Flow is from I to 3 or from 3 to I. Port 2 is closed.

**Solenoid Energized:** Flow is from I to 2 or from 2 to I. Port 3 is closed.

## Flow Diagrams

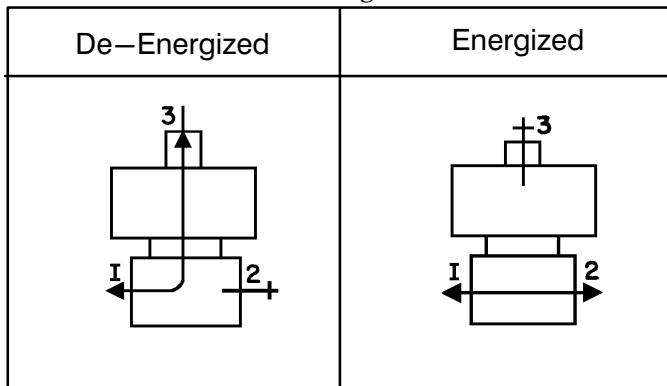

## INSTALLATION

Check nameplate for correct catalog number, pressure, voltage, frequency, and service. Never apply incompatible fluids or exceed pressure rating of the valve. Installation and valve maintenance to be performed by qualified personnel.

### Temperature Limitations

Fluid and ambient temperature range: -40°F to +140°F.

### Future Service Considerations

Provision should be made for performing seat leakage, external leakage, and operational tests on the valve with a nonhazardous, noncombustible fluid after disassembly and reassembly.

### Positioning

Valve may be mounted in any position.

### Mounting

Refer to Figure 1 for mounting brass valve with mounting bracket or directly to valve body. Refer to Figure 2 for mounting stainless steel valve with mounting bracket.

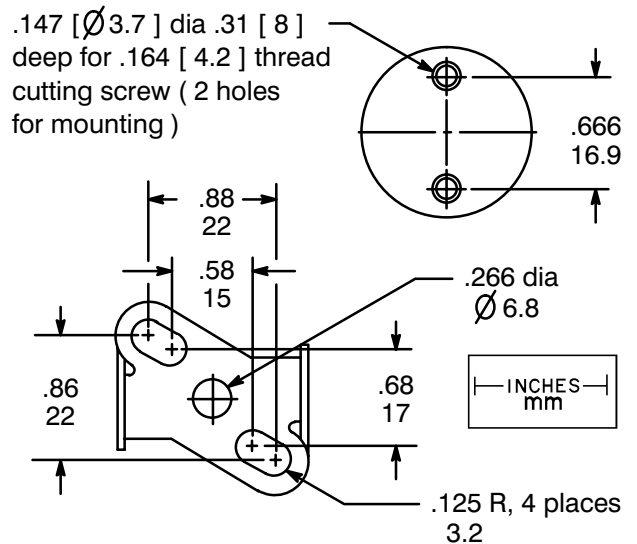

Figure 1. Dimensions for direct mounting to valve body or mounting bracket for brass valve construction.

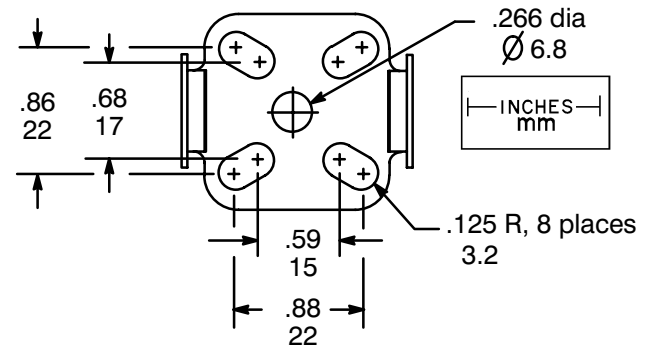

Figure 2. Mounting bracket dimensions for stainless steel valve.

## Piping

Connect piping or tubing to valve according to markings on valve body. Refer to flow diagrams in **OPERATION** section.

**⚠ CAUTION:** To avoid damage or accidental disengagement of cartridge assembly from valve body, hold cartridge assembly securely by wrenching flats when installing or removing piping at Port 3.

Apply pipe compound sparingly to male pipe threads only. If applied to valve threads, the compound may enter the valve and cause operational difficulty. Avoid pipe strain by properly supporting and aligning piping. When tightening the pipe, do not use valve or solenoid as a lever. Locate wrenches applied to valve body or piping as close as possible to connection point.

**IMPORTANT:** These solenoid valves are intended for use on clean dry air or inert gas, filtered to 50 micrometres or better. The dew point of the media should be at least 10° C (18° F) below the minimum temperature to which any portion of the clean air/inert gas system could be exposed to prevent freezing. If lubricated air is used, the lubricants must be compatible with Buna N elastomers. Diester oils may cause operational problems. Instrument air in compliance with ANSI/ISA Standard S7.3–1975 (R1981) exceeds the above requirements and is, therefore, an acceptable media for these valves.

### MAINTENANCE

**▲ WARNING:** To prevent the possibility of personal injury or property damage, turn off electrical power, depressurize valve, and vent fluid to a safe area before servicing the valve.

NOTE: It is not necessary to remove the valve body from the pipeline for repairs. However, piping or tubing must be removed from Port 3 connection.

#### Cleaning

All solenoid valves should be cleaned periodically. The time between cleanings will vary depending on the medium and service conditions. In general, if the voltage to the coil is correct, sluggish valve operation, excessive noise or leakage will indicate that cleaning is required. In the extreme case, faulty valve operation will occur and the valve may fail to shift. Clean strainer or filter when cleaning the valve.

#### Preventive Maintenance

- Keep the medium flowing through the valve as free from dirt and foreign material as possible.
- While in service, the valve should be operated at least once a month to insure proper opening and closing.
- Depending on the medium and service condition, periodic inspection of internal valve parts for damage or excessive wear is recommended. Thoroughly clean all parts. If parts are worn or damaged, install a complete ASCO Rebuild Kit.

#### Causes of Improper Operation

- **Incorrect Pressure:** Check valve pressure. Pressure to valve must be within range specified on nameplate.
- **Excessive Leakage:** Disassemble valve and install a complete ASCO Rebuild Kit.

#### Valve Disassembly

1. Disassemble valve in an orderly fashion using exploded view for identification and placement of parts.
2. Remove solenoid, see separate instructions.
3. Unscrew cartridge assembly from valve body. Then remove cartridge gasket and orifice gasket.
4. Clean valve and install a complete ASCO Rebuild Kit.

#### Valve Reassembly

1. Lubricate all gaskets with DOW CORNING® 111 Compound lubricant or an equivalent high-grade silicone grease.
2. Position cartridge gasket in valve body.
3. Install orifice gasket in recess in base of cartridge assembly.
4. Thread cartridge assembly with orifice gasket into valve body. Then torque cartridge assembly to 175 ± 25 in-lbs [19,8 ± 2,8 Nm].
5. Install solenoid see separate instructions. Then make up piping and electrical connection to solenoid.

**▲ WARNING:** To prevent the possibility of personal injury or property damage, check valve for proper operation before returning to service. Also perform internal seat and external leakage tests with a nonhazardous, noncombustible fluid.

6. Restore line pressure and electrical power supply to valve.
7. After maintenance is completed, operate the valve a few times to be sure of proper operation.

#### ORDERING INFORMATION FOR ASCO REBUILD KITS

Parts marked with an asterisk (\*) in the exploded view are supplied in Rebuild Kits. When Ordering Rebuild Kits for ASCO valves, order the Rebuild Kit number stamped on the valve nameplate. If the number of the kit is not visible, order by indicating the number of kits required, and the Catalog Number and Serial Number of the valve(s) for which they are intended.

### Torque Chart

Part Name	Torque Value In-lbs	Torque Value Nm
Cartridge Assembly	175 ± 25	19,8 ± 2,8

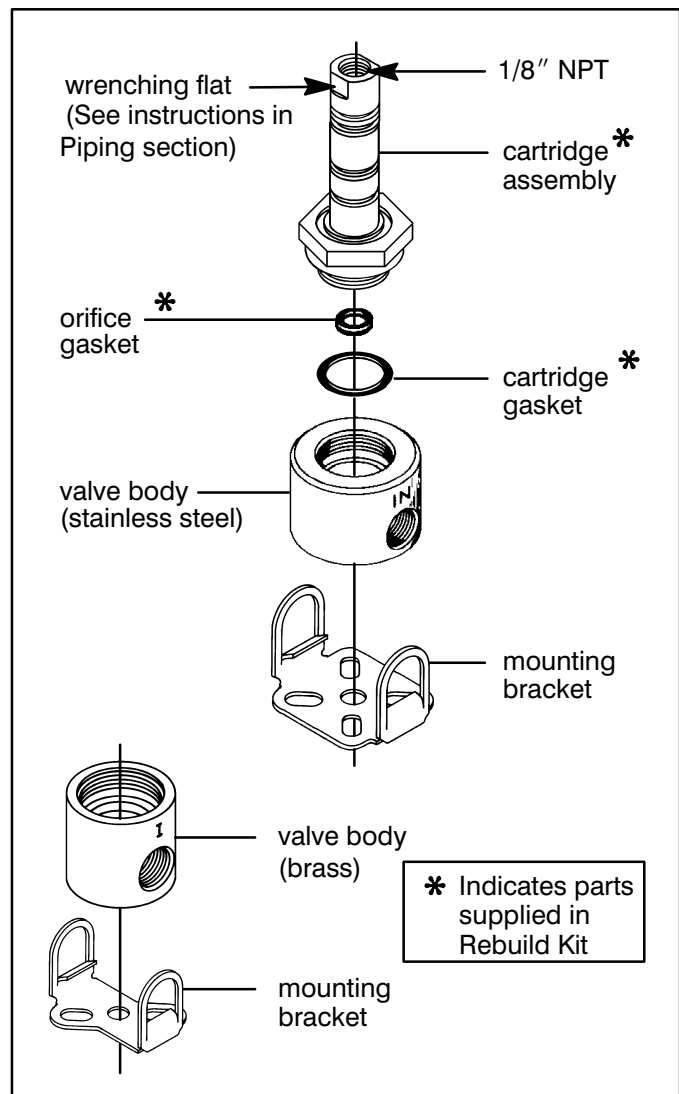

Figure 3. Series 8314 without solenoid.